

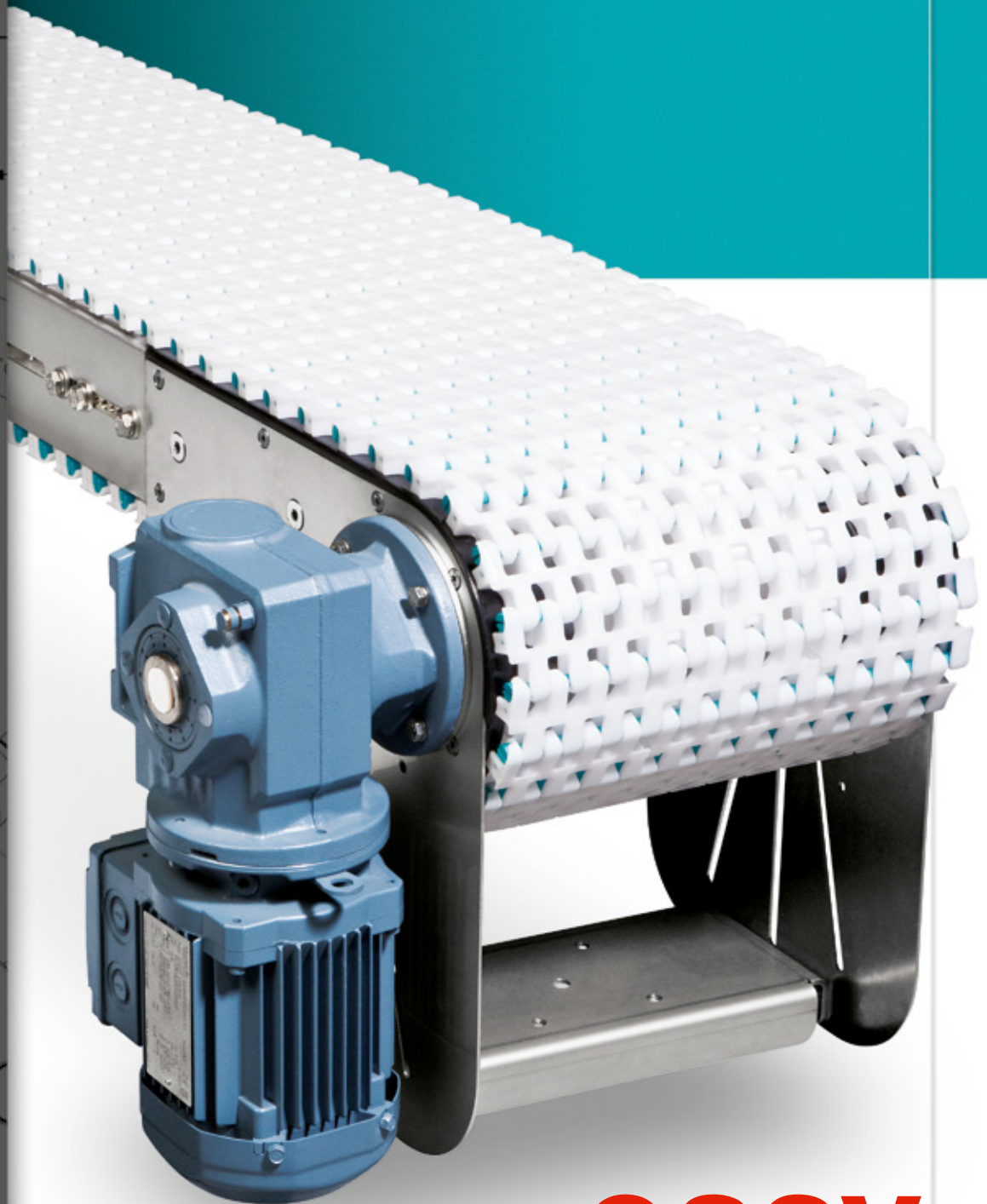

EMBS
SYSTEM

MAT TOP CONVEYORS

Stainless steel & aluminium



easy
...CONVEYORS

www.easy-conveyors.com



Easy Conveyors is an extremely flexible conveyor system that consists of a number of easy to assemble basic units. By combining various components, it's actually only your imagination that set the limits.

MAT TOP CONVEYORS

EMBS Head Drive

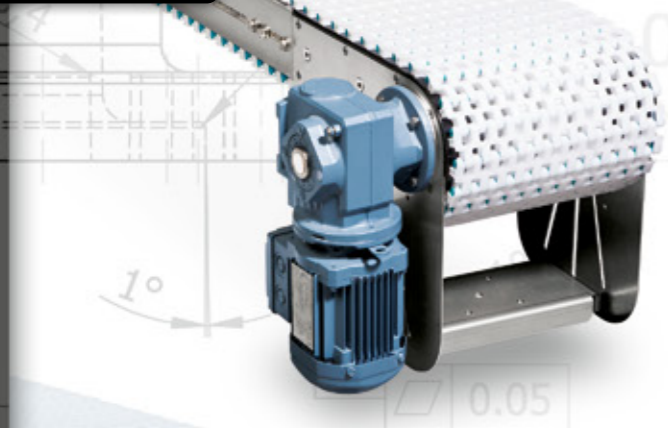

The standard conveyors from Easy conveyors are based on aluminium or stainless steel profiles with low friction slide rails guiding a plastic multi-flexing chain. Easy conveyors has a long experience of plastic chain conveyor systems through researching, developing, manufacturing and installing. All conveyor systems are thoroughly tried and tested, to ensure you get a system with a long service life and low maintenance.

The conveyor systems are based on a close-fitting, multiflex plastic chain conveyor that gives a straight, horizontal and vertical running capability. Horizontal bends allow routing close to machines, saving floor space. Vertical bends also save floor space by enabling multilevel transportation and make access easy for operators. These multiflexing conveyor systems use plastic chains in many configurations. The chain design permits horizontal as well as vertical change of direction. Chain widths range from 255 up to 510 mm, for product widths up to 700 mm. Each system consists of a wide range of modular components which can be fitted using simple hand tools.

Aluminium system

This aluminium conveyor systems uses a plastic chain that permits horizontal as well as vertical change of direction. In addition to the standard types, several special purpose chain links are available on request. The available wide is 255, 340, 425 and 510 mm.

Aluminium system

Stainless steel system

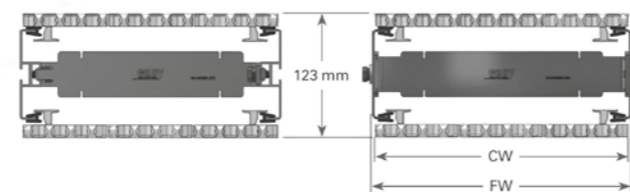

Examples of products handled

Bearings, packed cookies, safety belt brackets, bread, Ice cream, electric motors, shock absorbers, steering arm components, boxes, Tissue paper, gear wheels, aerosol cans, meat, yoghurt, fuel injectors, dry batteries, plastic bottles, matches, cheese boxes, coffee and tea packages, Wide products such as large cardboard boxes, products in soft plastic bags, for example detergent powder, wrapped tissue paper rolls, food products, personal care products.



EMBS Center Drive

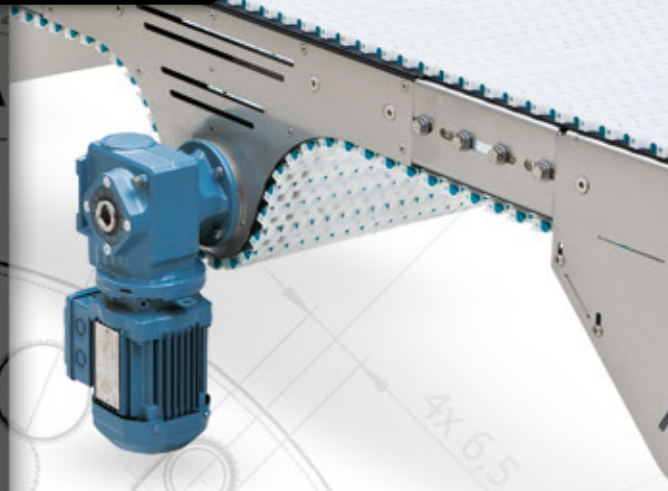

EMBS Connection Drive

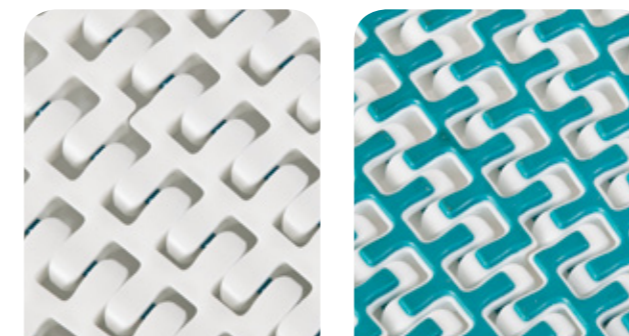

Stainless Steel System (Hygienic conveyor design)

The Stainless steel conveyors Series is a conveyor adapted to the requirements of the food processing, pharmaceutical and hygiene industries.

The system is designed for easy integration with aluminium systems, and there are many chain types available from the standard range. It is designed according to the EHEDG* guidelines. The EMBS wash down systems are hygienic, industry standard conveyor systems.

The stainless steel Series is ideal for filling lines within the food, personal products and liquid pharmaceuticals segments.



Easy de-assembling everywhere in the conveyor.

Technical characteristics EMBS series

	255	340	425	510
Drive unit capacity	1250 N	1250 N	1250 N	1250 N
Chain tension limit	2500 N	2500 N	2500 N	2500 N
Frame width (FW)	260 mm	344 mm	429 mm	513 mm
Chain width (CW)	255 mm	340 mm	425 mm	510 mm
Item width	< 400 mm	< 500 mm	< 600 mm	< 700 mm
Maximum conveyor length*	20 m	20 m	20 m	20 m

* depending on the lay out

Examples of products handled

Aerosol cans, liquid soap in plastic bags, soft cheese, detergent powder, tissue paper rolls, food products, PET bottles, personal care products.

Conveyor with custom made supports and side guiding.



*) European Hygiene Engineering and Design Group, an EU machine directive for safe and hygienic machinery.

easy
...CONVEYORS



www.easy-conveyors.com
 Phone: +31 (0)40 - 283 83 19
 Telefax: +31 (0)40 - 283 59 99
 E-mail: info@easy-conveyors.com

EASY CONVEYORS
 Collse Heide 54
 5674 VN Nuenen
 The Netherlands



**CONFIGURE
YOUR CONVEYOR ONLINE:**
www.easy-conveyors.com

Go to www.easy-conveyors.com
 Go to productrange and click on the product configurator

- STEP 1** Go to Product & CAD and choose your type of conveyor
- STEP 2** Choose your type of conveyor
- STEP 3** Select the parameters
- STEP 4** Select the parameters
- STEP 5** Select the parameters
- STEP 6** Click right below on CAD file or Data sheet, in a few seconds your CAD drawing or datasheet will be ready at the left side for downloading.
- STEP 7** Download your 3D drawing of your designed conveyor

