

Configure your conveyor online:

[www.easy-conveyors.com](http://www.easy-conveyors.com)



- Step 1 Go to [www.easy-conveyors.com](http://www.easy-conveyors.com) and click on ENGINEERING ONLINE.
- Step 2 Go to Product & CAD and choose your type of conveyor.
- Step 3 Choose your type of conveyor.
- Step 4 Choose your model.
- Step 5 Choose your cad format and configure your conveyor.
- Step 6 Click right below on CAD file or Data sheet, in a few seconds your CAD drawing or datasheet will be ready at the left side for downloading.
- Step 7 Download your 3D drawing of your designed conveyor.



# table top conveyor

stainless steel & aluminium

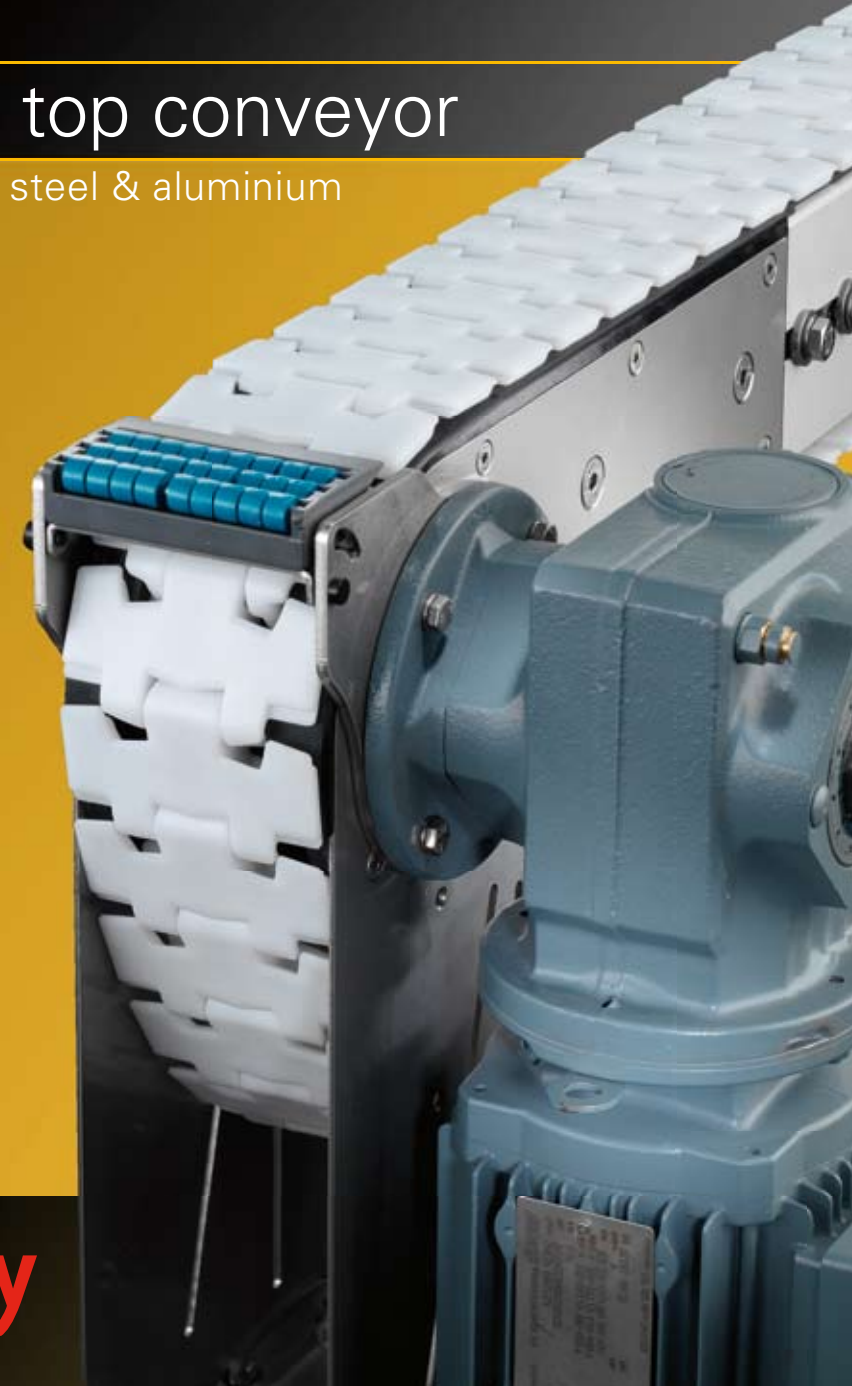



**EASY CONVEYORS IS AN EXTREMELY FLEXIBLE CONVEYOR SYSTEM THAT CONSISTS OF A NUMBER OF EASY TO ASSEMBLE BASIC UNITS. BY COMBINING VARIOUS COMPONENTS, IT'S ACTUALLY ONLY YOUR IMAGINATION THAT SET THE LIMITS.**

The standard conveyors from Easy conveyors are based on an aluminium or stainless steel profiles with low friction slide rails guiding a plastic multi-flexing chain. Easy conveyors has a long experience of plastic chain conveyor systems through researching, developing, manufacturing and installing. All conveyor systems are thoroughly tried and tested, to ensure you get a system with a long service life and low maintenance.

The conveyor systems are based on a close-fitting, multiflex plastic chain conveyor that gives a straight, horizontal and vertical running capability. Tight horizontal bends allow routing close to machines, saving floor space. Tight vertical bends also save floor space by enabling multilevel transportation and make access easy for operators. These multiflexing conveyor systems use plastic chains in many

configurations. The chain design permits horizontal as well as vertical change of direction. Chain widths range from 80 up to 200 mm, for product widths up to 400 mm. Each system consists of a wide range of modular components which can be fitted using simple hand tools.

*aluminium system with sliding and wheel curve*



**ALUMINIUM SYSTEM**

This aluminium conveyor systems uses a plastic chain that permits horizontal as well as vertical change of direction. In addition to the standard types, several special purpose chain links are available on request. The available wide is 80, 140 and 200 mm.

**Examples of products handled**

Bearings, packed cookies, safety belt brackets, electric motors, shock absorbers, steering arm components, boxes, gear wheels, aerosol cans, meat, yoghurt, fuel injectors, dry batteries, plastic bottles, coffee and tea packages, Wide products such as large cardboard boxes, products in soft plastic bags, for example detergent powder, wrapped tissue paper rolls, food products, personal care products

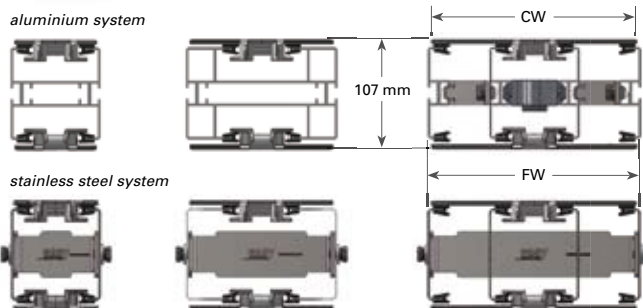

**finger safe multiflexing chain**

**STAINLESS STEEL SYSTEM (HYGIENIC CONVEYOR DESIGN)**

The stainless steel conveyors series is a conveyor adapted to the requirements of the food processing, pharmaceutical and hygiene industries. The system is designed for easy integration with aluminium systems, and there are many chain types available from the standard range. It is designed according to the EHEDG\* guidelines. The 80, 140 and 200 mm wash down systems are hygienic, industry standard conveyor systems. The stainless steel series is ideal for filling lines within the food, personal products and liquid pharmaceuticals segments

\*) European Hygiene Engineering and Design Group, an EU machine directive for safe and hygienic machinery.



Technical characteristics	80	140	200
Drive unit capacity	1500 N	1500 N	1500 N
Chain tension limit	3000 N	3000 N	3000 N
Frame width (FW)	87,5 mm	147,5 mm	207,5 mm
Chain width (CW)	80 mm	140 mm	200 mm
Item width	20 - 200 mm	70 - 300 mm	100 - 400 mm
Max. item weight horizontal transport	15 kg	15 kg	15 kg
Max. conveyor length	30 m	30 m	30 m

\* depending on the lay out



*stainless steel sliding curve*



**Examples of products handled**

Aerosol cans, liquid soap in plastic bags, soft cheese, detergent powder, tissue paper rolls, food products, personal care products, PET bottles.

