

belt conveyors

ECA



ECA40-I2

Indirect Drive

Belt conveyors are ideal for linear, horizontal or even as incline transport of goods. Easy conveyors has developed a wide range of modular conveyor systems with synthetic belts. Key concept of the system is quick and easy to assemble thanks to modular design, high performance, safe and low noise level are the characters of the systems.

The ECA 40-I2 serie is the conveyor for the medium load and a maximum length of 8 meters with a maximum wide of 500 mm. The rollers have a diameter of 15 and 45 mm. The frame is build up out of aluminum anodized profiles with a slide at the side where you can mount the side guiding and the supports

ECA 40 FRAME

ECA 40 SIDE PROFILE

Material: Aluminum, 12 micron anodized
 Fabrication size = center to center minus 70 mm (A)
 Package: 1 piece
 Profile ECA 40 L=5600 mm; VE=5 **ECA04090000**

ECA 40 COUPLE SET

Material: Aluminium, 12 micron anodized
 Package: 1 connector, 2 brackets with fasteners

Connector B = 200 mm	ECA04090020
Connector B = 300 mm	ECA04090030
Connector B = 400 mm	ECA04090040
Connector B = 500 mm	ECA04090050

PROFILE CONNECTOR SET

Material: Steel, galvanized
 Package: 2 pieces with fastener

Profile connector set	EMPT040705000006
-----------------------	-------------------------

SLIDENUT

Material: Steel, galvanized
 Package: 25 pieces

Slide nut M6	040115000001
Slide nut M8	040115000002

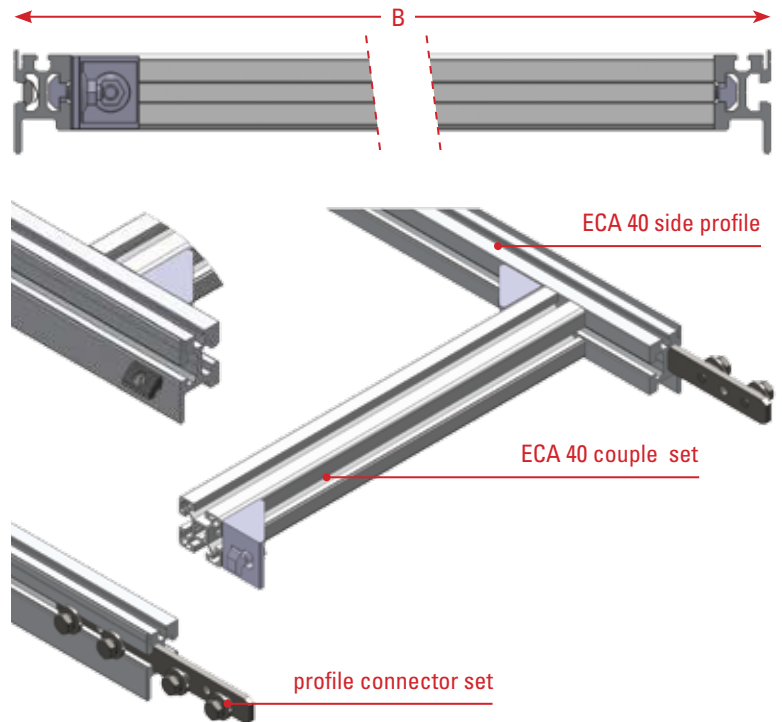

ECA 40 DRIVE

IDLER UNIT 15

Material: Aluminum die cast
 Package: Left and right support plate with fasteners
ROLLER NOT INCLUDED **ECA04091000S**

IDLER ROLLER 15

Material: Stainless steel rollers, 1 support roller, including fasteners
 Package: 1 piece, diameter 15 mm

Idler roller set knife edge B-200 mm	ECP04091020S
Idler roller set knife edge B-300 mm	ECP04091030S
Idler roller set knife edge B-400 mm	ECP04091040S
Idler roller set knife edge B-500 mm	ECP04091050S

SUPPORT ROL

Material: Stainless steel shaft with aluminum cover tube
 Package: per piece

Length: Support axe B-200 mm	ECA00093020
Length: Support axe B-300 mm	ECA00093030
Length: Support axe B-400 mm	ECA00093040
Length: Support axe B-500 mm	ECA00093050
Length: Support axe B-600 mm	ECA00093060

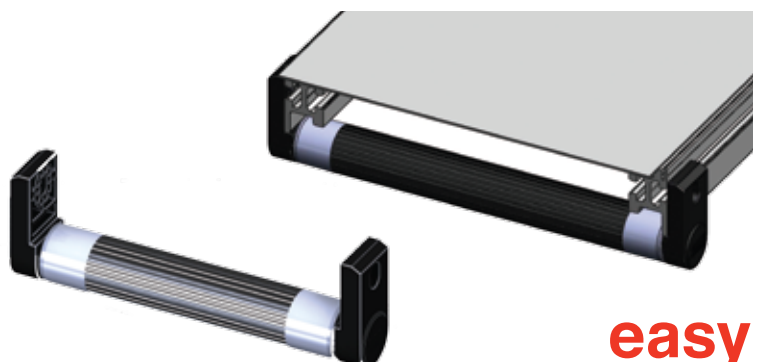
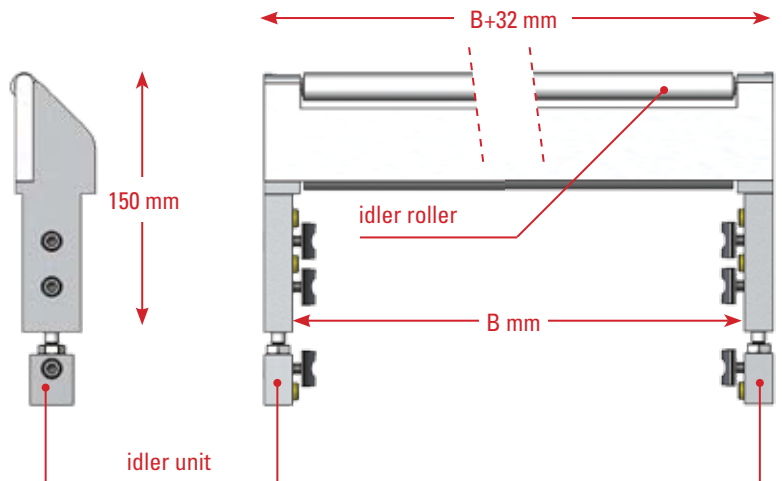

ECA 40 DRIVE UNIT

INDIRECT DRIVE UNIT 40

Material: Aluminum die cast
 Package: Left and right support plate with fasteners,
 2x tooth wheel and tooth belt including
 belt tensioner

Indirect drive set right	ECA04082000S
Indirect drive set left	ECA04083000S

ROLLER AND GEARMOTOR NOT INCLUDED
 FOR GEARMOTORS SEE SHEET "GEARMOTORS"

INDIRECT DRIVE ROLLER

Material: Stainless steel shaft with aluminum cover tube
 Package: 1 drive roller diameter 65 mm,
 1 support roller diameter 35 mm

Indirect drive roller set 200 mm	ECP04082020S
Indirect drive roller set 300 mm	ECP04082030S
Indirect drive roller set 400 mm	ECP04082040S
Indirect drive roller set 500 mm	ECP04082050S

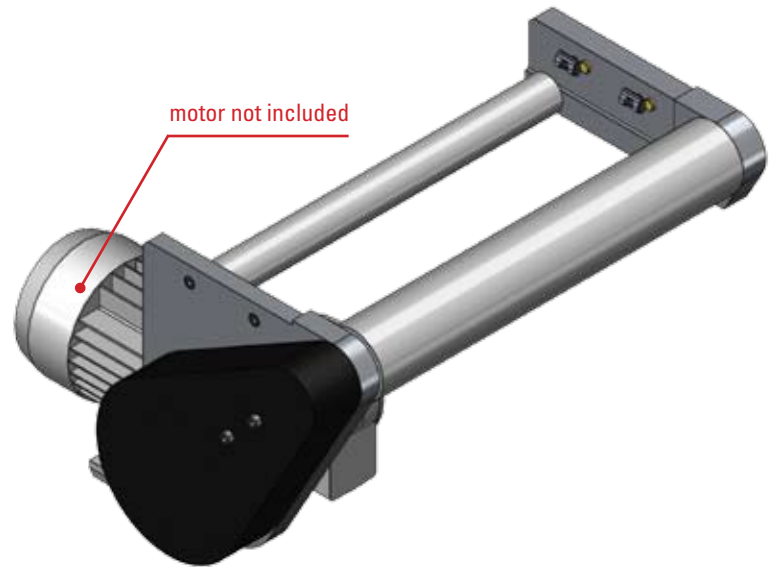
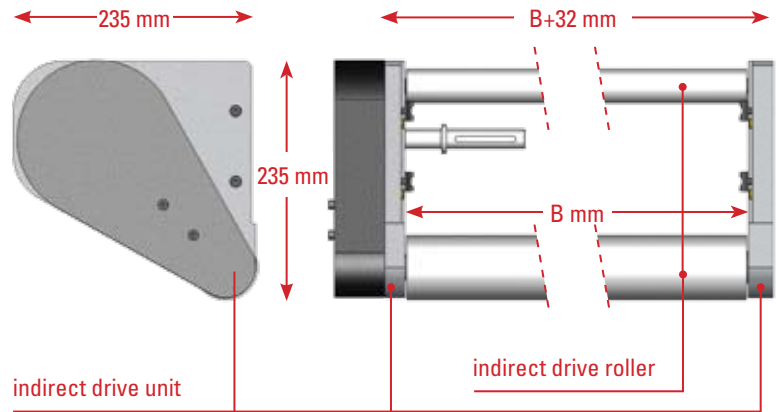

ECA TOP PLATE + BELT

ECA TOP PLATE TAPE

Material: 2 sided tape
 Package: 1 roll of 33 meters **ECA00092100**

ECA TOP PLATE 40

Material: Steel galvanized 2 mm
 Package: on request
 Fabrication size A-45 mm, B-5 mm **ECA00092000**

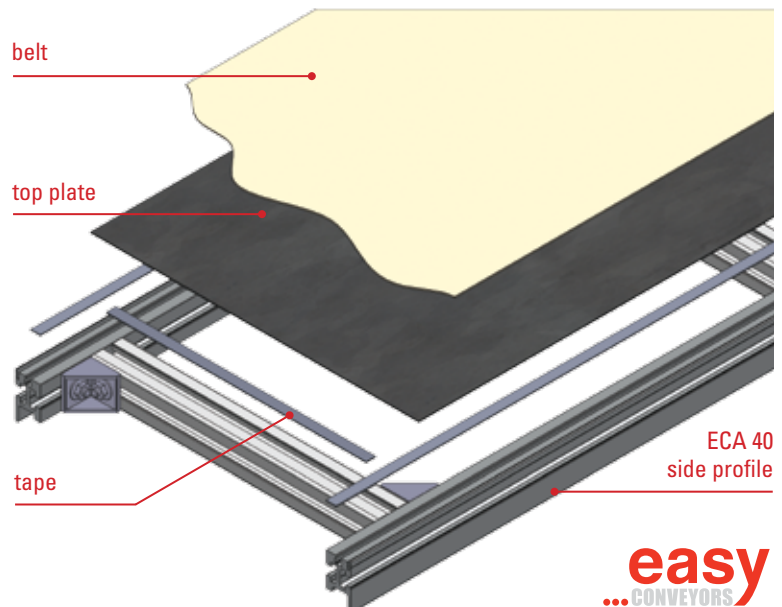
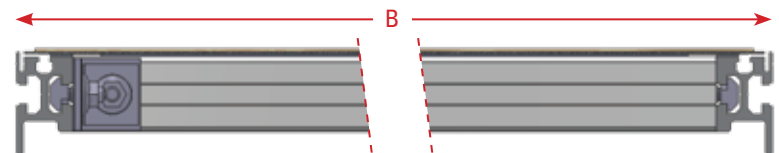

FOR BELT MATERIAL SEE PRODUCTSHEET
 "BELT MATERIAL"

FOR GEARMOTORS SEE PRODUCTSHEET
 "GEARMOTORS"

FOR SIDE GUIDING SEE PRODUCTSHEET
 "SIDE GUIDING"

ECA40-12

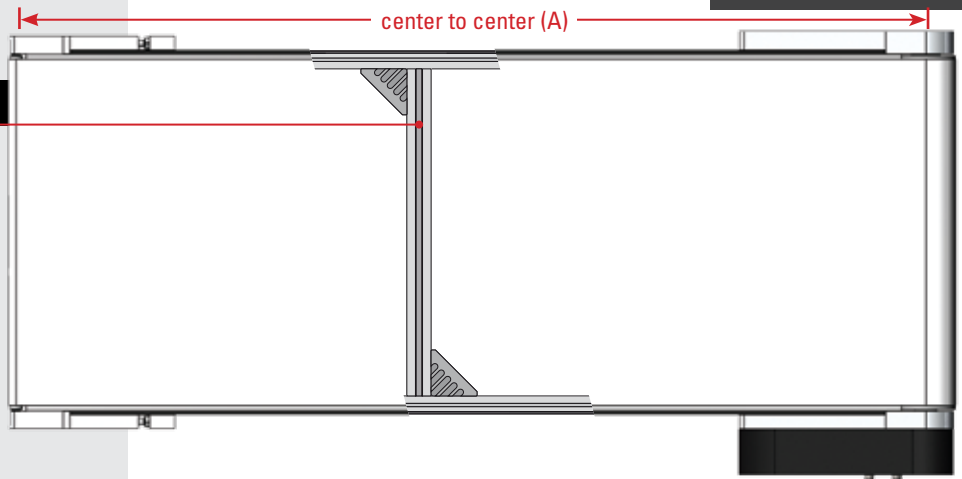

ECA COUPLE SET

ECA KNIFE EDGE

ECA KNIFE EDGE

ECA PROFILE

ECA TOP PLATE & BELT

ECA DRIVE UNIT